

RCD/RCG Plus Technical Data Diesel and LPG Forklift Trucks

RCD/RCG 25 Plus

RCD/RCG 30 Plus

RCD/RCG 35 Plus





				STILL	STILL	STILL	STILL	STILL	STILL		
				RCD 25 Plus	RCD 30 Plus	RCD 35 Plus	RCG 25 Plus	RCG 30 Plus	RCG 35 Plus		
Features	1.1	Manufacturer									
	1.2	Manufacturer's type designation									
	1.3	Drive		Diesel	Diesel	Diesel	LPG	LPG	LPG		
	1.4	Operation		Seated	Seated	Seated	Seated	Seated	Seated		
	1.5	Load capacity/load	Q	kg	2500	3000	3500	2500	3000	3500	
	1.6	Load centre distance	c	mm	500	500	500	500	500	500	
	1.8	Load distance	x	mm	494	504	509	494	504	509	
	1.9	Wheel base	y	mm	1760	1760	1760	1760	1760	1760	
	Weights	2.1	Service weight		kg	4250	4620	5060	4180	4680	5040
2.2		Axle load, laden	front/rear	kg	5820/840	6660/940	7420/1160	5860/840	6700/960	7400/1140	
2.3		Axle load, unladen	front/rear	kg	1990/2260	1940/2680	1880/3180	1880/2300	1980/2700	1840/3200	
Wheels/chassis	3.1	Tyres			Superelastic	Superelastic	Superelastic	Superelastic	Superelastic		
	3.2	Tyre size	front		28x9-15	28x9-15	28x9-15	28x9-15	28x9-15		
	3.3	Tyre size	rear		6.5-10	6.5-10	6.5-10	6.5-10	6.5-10		
	3.5	Number of wheels (x = driven)			2x/2	2x/2	2x/2	2x/2	2x/2		
	3.6	Track width	front	b ₁₀	mm	1030	1030	1030	1030	1030	
	3.7	Track width	rear	b ₁₁	mm	953	953	953	953	953	
Basic dimensions	4.1	Tilt of mast/fork carriage	forward/backward	α/β	°	6/12	6/12	6/12	6/12	6/12	
	4.2	Height of mast	mast retracted	h ₁	mm	2137	2137	2137	2137	2137	
	4.3	Free lift		h ₂	mm	150	150	150	150	150	
	4.4	Lift		h ₃	mm	3000	3000	3000	3000	3000	
	4.5	Height of mast	mast extended	h ₄	mm	3715	3715	3715	3715	3715	
	4.7	Height of overhead guard (cabin)		h ₆	mm	2221	2221	2221	2221	2221	
	4.8	Seat height rel. to SIP/stand height		h ₇	mm	1223	1223	1223	1223	1223	
	4.12	Coupling height		h ₁₀	mm	310	310	310	310	310	
	4.19	Overall length		l ₁	mm	3735	3745	3830	3735	3745	3830
	4.20	Length including fork backs		l ₂	mm	2735	2745	2830	2735	2745	2830
	4.21	Overall width		b ₁ /b ₂	mm	1265	1265	1265	1265	1265	1265
	4.22	Fork dimensions		s/e/l	mm	45/100/1000	45/122/1000	50/150/1000	45/100/1000	45/122/1000	50/150/1000
	4.23	Fork carriage ISO 2328, class/form A, B				IIA	IIIA	IIIA	IIA	IIIA	
	4.24	Fork carriage width		b ₃	mm	1040	1100	1100	1040	1100	1100
	4.31	Ground clearance below mast, laden		m ₁	mm	146	145	144	146	145	144
	4.32	Ground clearance, centre of wheel base		m ₂	mm	163	161	159	163	161	159
4.33	Working aisle width with 1000 x 1200 pallet crossways		A _{st}	mm	4145	4145	4220	4145	4145	4220	
4.34	Working aisle width with 800 x 1200 pallet lengthways		A _{st}	mm	4345	4345	4420	4345	4345	4420	
4.35	Turning radius		W _a	mm	2440	2440	2510	2440	2440	2510	
4.36	Smallest pivot point distance		b ₁₃	mm	673,5	673,5	673,5	673,5	673,5	673,5	
Performance data	5.1	Driving speed	laden/unladen	km/h	17/17.5	17/17.5	17/17.5	18.3/18.5	18.3/18.5	18.3/18.5	
	5.2	Lifting speed	laden/unladen	m/s	0.50/0.55	0.50/0.55	0.50/0.55	0.50/0.58	0.45/0.58	0.40/0.58	
	5.3	Lowering speed	laden/unladen	m/s	0.40/0.45	0.40/0.45	0.40/0.45	0.40/0.45	0.40/0.45	0.40/0.45	
	5.5	Drawbar pull	laden/unladen	N	16700/11200	16500/11100	16300/10900	14960/12080	14965/13589	16415/12935	
	5.7	Gradeability	laden/unladen	%	26/26	22/24	20/22	22/24	20/22	18/20	
	5.9	Acceleration time	laden/unladen	s	4.4/3.5	4.8/3.8	5.2/4.3	5.4/4.6	5.6/4.8	5.7/5.1	
5.10	Service brake				Mechanical/hydraulic	Mechanical/hydraulic	Mechanical/hydraulic	Mechanical/hydraulic	Mechanical/hydraulic		
IC engine	7.1	Engine manufacturer/type			Doosan/D24 EU5	Doosan/D24 EU5	Doosan/D24 EU5	Doosan/PM02-MFF04	Doosan/PM02-MFF04	Doosan/PM02-MFF04	
	7.2	Engine performance in accordance with ISO 1585		kW	45	45	45	40.2	40.2	40.2	
	7.3	Nominal speed		l/min	2400	2400	2400	2600	2600	2600	
	7.4	Number of cylinders/capacity		cm ³	4/2400	4/2400	4/2400	4/2392	4/2392	4/2392	
	7.5	Fuel consumption in accordance with EN 16796		l/h	3.3	3.6	4.1	3.15	3.65	3.75	
	7.6	Handling capacity in accordance with EN 16796		t/h	198	238	281	183	215	238	
	7.7	Energy consumption at handling capacity in accordance with EN 16796		t/l	33	39	41	44	46	56	
	7.10	Battery voltage/nominal capacity		V/Ah	12/90	12/90	12/90	12/90	12/90	12/90	
8.1	Type of drive unit			Hydrodynamic	Hydrodynamic	Hydrodynamic	Hydrodynamic	Hydrodynamic	Hydrodynamic		
Miscellaneous	10.1	Operating pressure for attachments		bar	165	185	205	165	185	206	
	10.2	Oil volume for attachments		l/min	30	30	30	30	30	30	
	10.4	Fuel tank, capacity		l/kg	62.7	62.7	62.7	11	11	11	
	10.7	Sound pressure level 1 L _{0A2} (operator's position) in accordance with EN 12053		dB(A)	85	85	85	88	88	88	

RCD/RCG Plus Diesel and LPG Forklift Trucks
Mast Tables



			Telescopic mast							HiLo mast					Triplex mast								
			3000	3250	3500	4000	4500	5000	5500	3000	3300	3500	4000	4500	4350	4500	4650	4800	5000	5500	6000	6500	
RCD/RCG 25 Plus	Nominal lift	h_3	mm	3000	3250	3500	4000	4500	5000	5500	3000	3300	3500	4000	4500	4350	4500	4650	4800	5000	5500	6000	6500
	Height	h_1	mm	2137	2237	2437	2737	2987	3237	3487	2102	2302	2402	2702	2952	2152	2202	2202	2202	2402	2652	2902	3102
	Free lift	h_2	mm	150	150	150	150	150	150	150	1353	1553	1653	1953	2203	1403	1453	1453	1453	1653	1903	2153	2353
	Free lift with load backrest	h_2	mm								1053	1253	1353	1653	1903	1103	1153	1153	1153	1353	1603	1853	2053
	Height, mast extended	h_4	mm	3715	3965	4215	4715	5215	5715	6215	3752	4052	4252	4752	5252	5102	5252	5402	5552	5752	6252	6752	7252
	Height, mast extended, with load backrest	h_4	mm	4045	4345	4545	5045	5545	6045	6545	4045	4345	4545	5045	5545	5395	5545	5695	5845	6045	6545	7045	7545
	Tilt angle	forward/backward	α/β																				
	Fork lock-in position centre-centre		mm	124/280/436/592/748/904							124/280/436/592/748/904					144/348/552/756/960							
	Fork lock-in position centre-centre (built-in sideshift)		mm	160/330/500/670/840							160/330/500/670/840					160/350/540/730/920							
	Tyres	front/rear		28X9-15/6,5-10							28X9-15/6,5-10					28X9-15/6,5-10							
	Track	front/rear	mm	1030/953							1030/953					1030/953							
	Maximum width	b_1	mm	1265							1265					1265							
RCD/RCG 30-35 Plus	Nominal lift	h_3	mm	3000	3250	3500	4000	4500	5000	5500	3000	3300	3500	4000	4500	4350	4500	4650	4800	5000	5500	6000	6500
	Height	h_1	mm	2137	2237	2437	2737	2987	3237	3487	2102	2302	2402	2702	2952	2152	2202	2202	2202	2402	2652	2902	3102
	Free lift	h_2	mm	150	150	150	150	150	150	150	1353	1553	1653	1953	2203	1403	1453	1453	1453	1653	1903	2153	2353
	Free lift with load backrest	h_2	mm								1053	1253	1353	1653	1903	1103	1153	1153	1153	1353	1603	1853	2053
	Height, mast extended	h_4	mm	3715	3965	4215	4715	5215	5715	6215	3752	4052	4242	4752	5252	5102	5252	5402	5552	5752	6252	6752	7252
	Height, mast extended, with load backrest	h_4	mm	4045	4295	4545	5045	5545	6045	6545	4045	4545	4545	5045	5545	5395	5545	5695	5845	6045	6545	7045	7545
	Tilt angle	forward/backward	α/β																				
	Fork lock-in position centre-centre		mm	144/348/552/756/960							144/348/552/756/960					144/348/552/756/960							
	Fork lock-in position centre-centre (built-in sideshift)		mm	160/350/540/730/920							160/350/540/730/920					160/350/540/730/920							
	Tyres	front/rear		28X9-15/ 6,5-10							28X9-15/ 6,5-10					28X9-15/ 6,5-10							
	Track	front/rear	mm	1030/953							1030/953					1030/953							
	Maximum width	b_1	mm	1265							1265					1265							

Technical Drawings

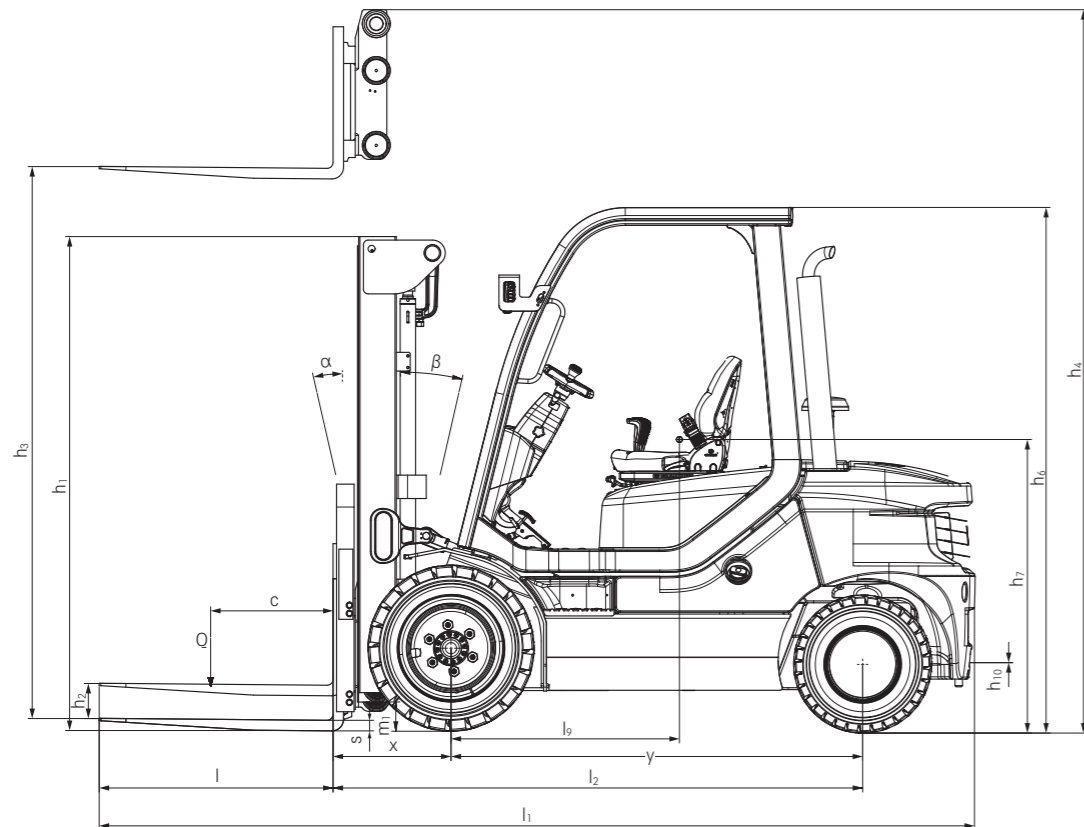

RCD/RCG Plus side view

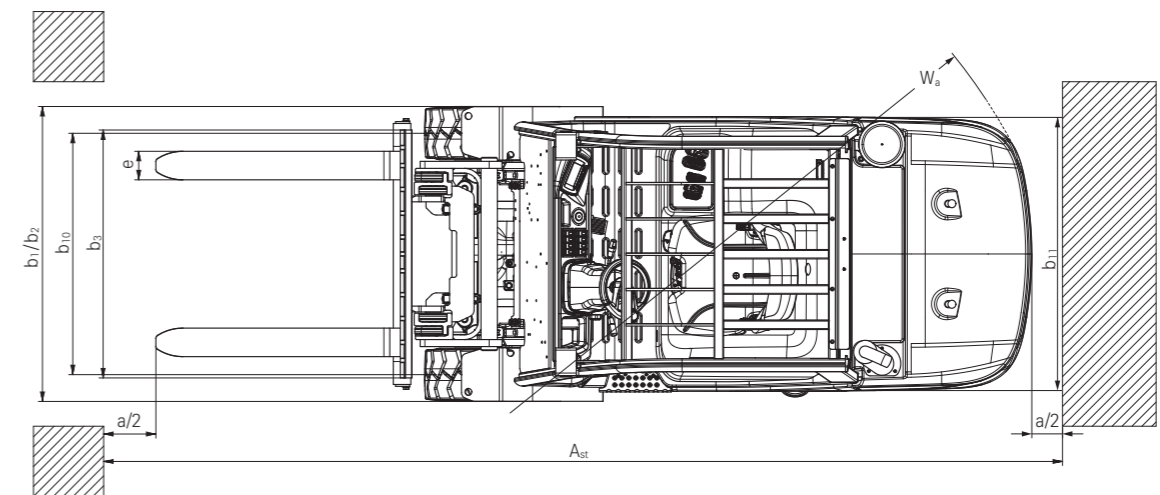

RCD/RCG Plus top view

RCD/RCG Plus Diesel and LPG Forklift Trucks

Basic Load Capacities

RCD/RCG 25 Plus
Telescopic/HiLo mast - Superelastic tyres

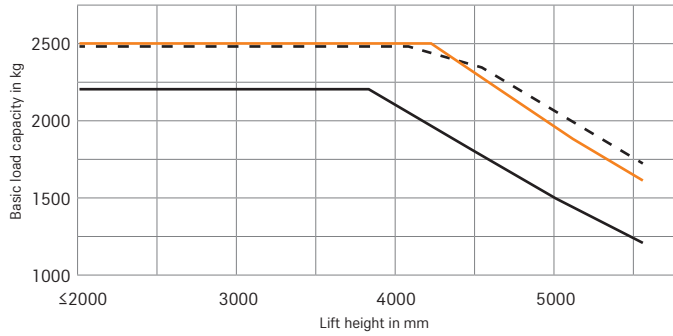

RCD/RCG 25 Plus
Triplex mast - Superelastic tyres

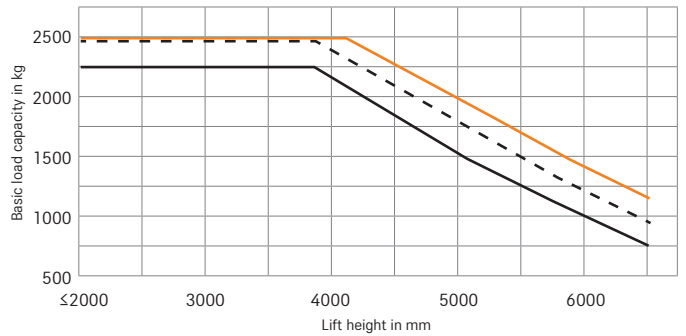

RCD/RCG 25 Plus
Triplex mast 4800 mm - Superelastic tyres

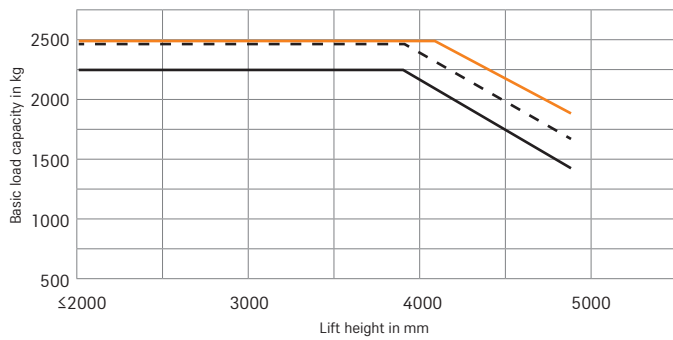

RCD/RCG 30 Plus
Telescopic mast - Superelastic tyres

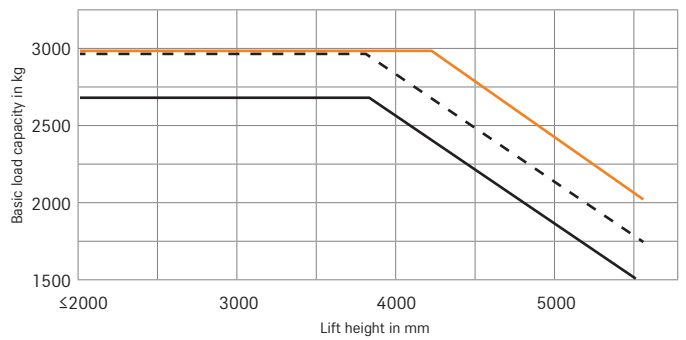

RCD/RCG 30 Plus
Triplex mast - Superelastic tyres

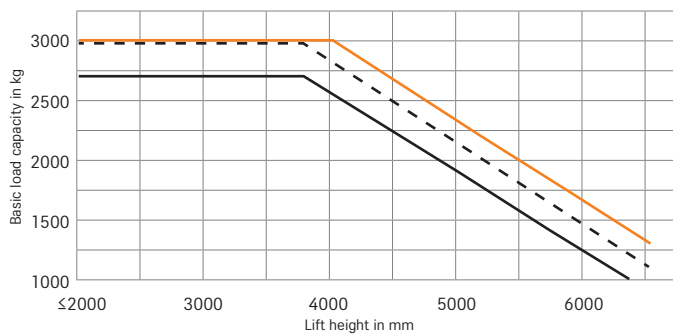

RCD/RCG 30 Plus
Triplex mast 4800 mm - Superelastic tyres

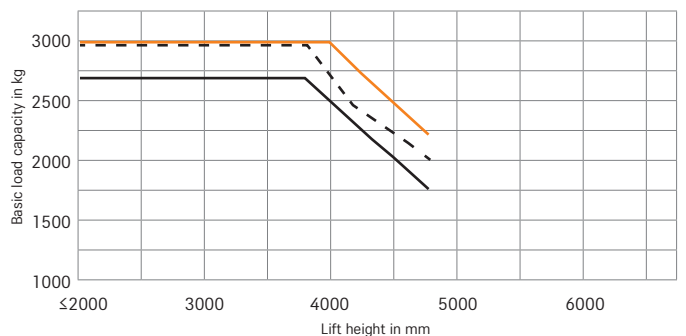

— Standard fork carriage - - - Integrated side shifter — Fitted side shifter
Values may vary depending on the truck equipment.

RCD/RCG 35 Plus
Telescopic mast - Superelastic tyres

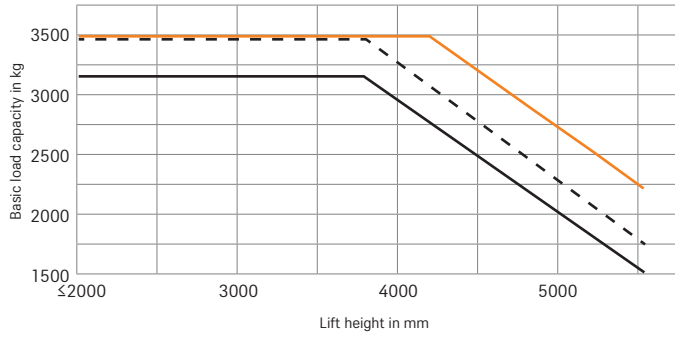

RCD/RCG 35 Plus
Triplex mast - Superelastic tyres

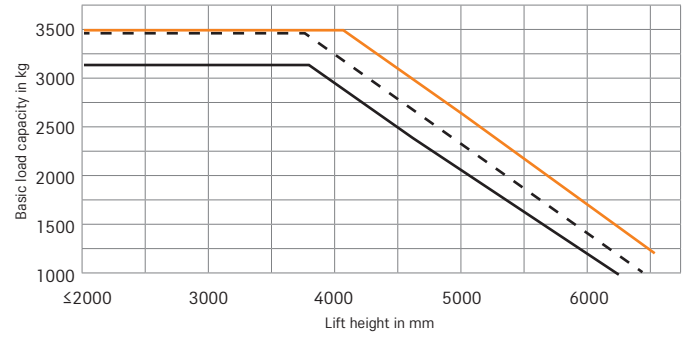

RCD/RCG 35 Plus
Triplex mast 4800 mm - Superelastic tyres

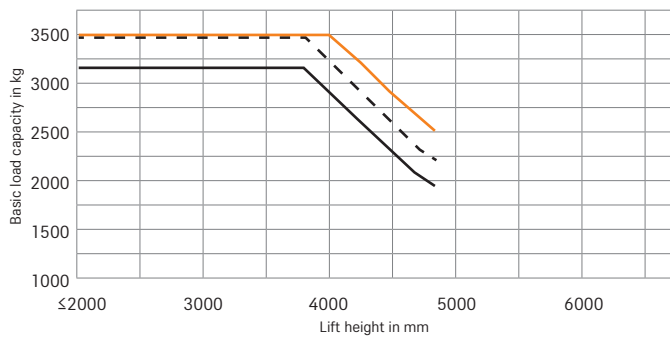

— Standard fork carriage - - - Integrated side shifter — Fitted side shifter
Values may vary depending on the truck equipment.

RCD/RCG Plus Diesel and LPG Forklift Trucks Detailed Photos



A conveniently positioned mast and a slightly offset operator's seat ensure good visibility

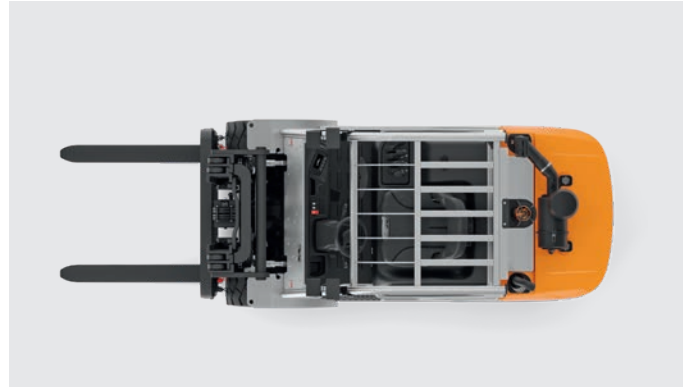

Narrow overhead guard bars allow the driver to have a clear view of everything up above



Ergonomically and intuitively designed operator's cab, where all control elements are in the field of vision and can be reached easily



Comfortable in every direction: The rear grab handle with integrated horn button ensures optimum safety and an ergonomic posture even when reversing



Comfortable entry and exit thanks to the grab handle and non-slip step edges



Direct transmission control: Quiet and smooth driving experience, even at low speeds and on ramps



Also available as an RCG with a powerful LPG engine



Ergonomic gas cylinder exchange: Swivelling fold-out holders make changing the LPG cylinder quick and easy

RCD/RCG Plus Diesel and LPG Forklift Trucks
The access to success



RCD/RCG Plus Diesel and LPG Forklift Trucks

The access to success

High performance: Powerful and reliable industrial engine

Everything in sight: Optimum view of forks and load carriers thanks to slim mast profile

Maximum safety: Robust overhead guard plus optional safety light



The RCD/RCG Plus is sure to put you on the road to success. A truck that has been developed for all those who are looking for a robust counterbalanced truck in the low-cost segment, ready for immediate use - without having to forgo the proven STILL quality. Available in a diesel or LPG version and with a lifting capacity of 2.5 to 3.5 tonnes, the RCD/RCG is a versatile allrounder that offers an unmatched price-performance ratio - and an extra 'plus' in terms of efficiency, user-friendliness and ergonomics. In addition to its powerful engine, the redesigned steering wheel and the most comfortable seat of this vehicle class add to this, as do the modern display with optimised user interface and the optional multi-lever control with

clamp release. Whether you are handling containers, trailers or pallets, on ramps or on the flat, you can count on this counterbalanced forklift truck to safely transport your goods to their destination. The suspension system for the operator's cab absorbs any jolts and vibrations caused by uneven floors; the hydraulic system is also very easy to control; and the operator enjoys excellent visibility on all sides. Furthermore, you can choose from a wide range of equipment options to suit your particular logistics planning requirements. It might be an entry-level truck, but with all these benefits, the RCD/RCG more than lives up to STILL's exceptional quality standards.

The 'Simply Efficient' factors: Performance attributes as a measure of economic efficiency



Simply easy

- Efficient, fatigue-free operation thanks to the ergonomically and intuitively designed operator's cab, where all control elements are in the field of vision and can be reached easily
- Ergonomic leg position and plenty of room to move in the spacious footwell
- Precise load handling and sensitive steering thanks to the separate inch pedal and the tried-and-tested STILL multi-lever hydraulics operation
- Unobstructed visibility for efficiency and safety: Large windows on all sides and narrow rear overhead guard bars provide a clear view of everything from the operator's seat
- High level of handling performance and safety thanks to the large colour display, which clearly summarises important information such as driving direction, fuel level and driving mode
- Direct transmission control: Quiet and smooth driving experience, even at low speeds and on ramps



Simply powerful

- Operational efficiency: The RCD/RCG 25-35 Plus can lift up to 3.5 tonnes with a load centre of 500 millimetres
- Impressive goods handling thanks to powerful, low maintenance industrial engines, a lifting height of up to 6.5 metres, as well as a maximum driving speed of 17 km/h - combined with excellent manoeuvrability
- Robust, long-lasting and low-maintenance: Use of durable materials for exposed components (steel instead of plastic) as well as additional covers for sensitive elements such as lights



Simply safe

- Very stable thanks to the truck's low centre of gravity
- Safe driving with the optional driver assistance function
- Reliable roll-away protection due to the mechanical, foot-operated parking brake
- Comfortable entry and exit thanks to the grab handle and non-slip step edges
- See and be seen: the RCD/RCG Plus can be equipped with further optional safety features such as panoramic rear-view mirrors, glass roof, sun visor and STILL Safety Light
- Comfortable in every direction: The rear grab handle with integrated horn button ensures optimum safety and an ergonomic posture even when reversing



Simply flexible

- Low-emission engine: Diesel and LPG engines both comply with Regulation (EU) 2016/1628 (Stage V emissions limits)
- Individual adjustment of the workplace thanks to three spacious storage areas and an infinitely adjustable steering column
- Driver comfort and ergonomic workplace: The operator's workplace can be flexibly adjusted to different operating conditions
- Safe and situational load handling thanks to the sensitive multi-lever operation



Simply connected

- Fast service analysis and parametrisation of settings thanks to CAN bus interface

RCD/RCG Plus Diesel and LPG Forklift Trucks

Equipment Variants



		Diesel RCD 25/30/35 Plus	LPG RCG 25/30/35 Plus
Driver's cab	Low operating costs due to low fuel consumption and long service intervals	●	●
	Steel overhead guard open on all sides	●	●
	Weather-protected or full cab with windscreen wiper/washer system	○	○
	Integrated storage	●	●
	4.3" colour display including operating hours counter	●	●
	Seat belt control	●	●
	MSG 65 Grammer seat with leatherette cover	●	●
	Grammer seat with textile cover and height-adjustable back extension	○	○
	Grab handle on front of protected roof	●	●
	Grab handle on back of protective roof with horn	●	●
	Document pocket	●	●
	USB port	●	●
	USB port and 12 V/10 A connection	○	○
	Removable clipboard	○	○
	Warm water heating	○	○
Mast	Free view mast available in telescopic, HiLo and triplex versions	○	○
	Load backrest	○	○
	Hydraulic coupling with either fixed connection or quick-release coupling	●	●
	Single or double ancillary hydraulics for telescopic, HiLo or triplex mast	○	○
	6/10 degrees front/rear tilt	●	●
	6/12 degrees front/rear tilt or 6/6 degrees front/rear tilt	○	○
Tyres	Load backrest	○	○
	Fork wear protection	○	○
	Superelastic, single tyres, SIT system	●	●
Operation	Superelastic, natural coloured, single tyres, SIT system	○	○
	Pneumatic tyres	○	○
Drive	Multi-lever operation	●	●
	Multi-lever operation with clamp release	●	●
	Powerful industrial diesel engine - complies with Euro 5 emissions limits	●	●
	Powerful industrial LPG engine - complies with Euro 5 emissions limits	—	●
	Regulated catalytic converter	—	●
	Diesel particle filter	●	●
	Raised exhaust pipe	●	●
	Low exhaust pipe	○	○
Brake	Diesel fuel tank, 62.7 litres	●	●
	Additional fuel filter	○	○
Safety	Ergonomic, foot-operated parking brake	●	●
	Mechanical/hydraulic service brake	●	●
	Low centre of gravity and steering axle with high self-aligning bearing for optimum safety	●	●
	Protective grille roof	○	○
	LED work lights and head lights	○	○
	Flashing light under the roof (protected)	○	○
	Speed limiter can be adjusted by service	○	○
	STILL Safety Light warning device	○	○
	Panoramic mirror	○	○
	Intelligent seat belt control	●	●
	Safety zone light: Warning light bars to the left and right of the truck	○	○
	Easybelt seat belt support system for quick and safe fastening and unfastening	○	○

● Standard ○ Option — Not available



STILL GmbH
Berzeliusstr. 10
22113 Hamburg
Germany
Tel.: +49 40 73 39 20 00
Fax: +49 40 73 39 20 01
info@still.de

For further information please visit
www.still.eu

STILL is certified in the following areas: Quality management, occupational safety, environmental protection and energy management.



first in intralogistics